

Designing Your Compressed Air System

How to Determine the System You Need



Determining Compressed Air Demand and Level of Air Quality

Supply, Storage, Distribution, and System Management

Layout and Installation Considerations

Glossary and Important Reference Data

KAESER COMPRESSORS

Built for a lifetime.™

Air Flow Measurement

Kaeser's air flow measurement system uses mass flow meters to record the actual amount of compressed air being used at any given time. Flow meters can be inserted into compressed air piping without interrupting system production, and output standard signals to a recording device that collects the data for review. Your local Kaeser representative can establish an accurate air demand profile and start improving system efficiency with a few simple steps.



Air Demand Analysis

Kaeser's exclusive Air Demand Analysis (ADA) provides a complete picture of a compressed air system's operation and performance. Highly accurate sensors and data loggers record flow, power consumption and pressure during normal operating conditions. Once the information is charted and analyzed, Kaeser engineers make recommendations for optimizing the system.

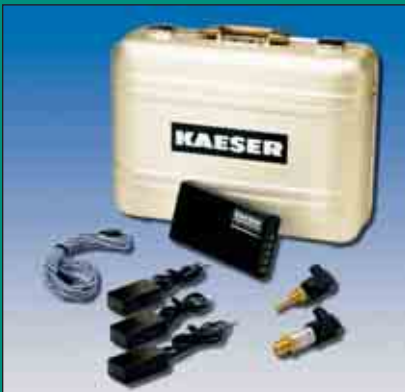

Designing Your Compressed Air System

Your compressed air system is a critical plant utility. To function properly and cost effectively, it must be carefully designed to fill the special needs of your applications. Six basic elements—demand, compressed air quality, supply, storage, distribution, and control/management—must be evaluated and factored into final layout considerations to give you optimum results at maximum efficiency. All six elements must work together for the system to reach top performance levels.

What Is Your Compressed Air Demand?

Determining the true demand in your compressed air system can be difficult but is a critical first step. Air demand often fluctuates significantly; however, if actual flow demand at any given time is known, storage and distribution systems can be designed to meet demand without installing additional compressors.

The most accurate method of establishing demand over time in an existing system is to monitor the air flow using a flow meter (see chart, pg. 3). Flow meters can be installed at various points in the system, but are typically installed in the main headers. Recorded data, such as air flow and pressure, can be evaluated to determine the flow

pattern. It is especially important to note the peaks and valleys in demand and their duration.

Electronic data loggers offer an effective means to track compressor activity over time. While they don't directly measure as many system parameters as flow meters, they provide substantial information to make an accurate assessment of system dynamics.

For smaller, less complex systems, the ratio between loaded and unloaded compressor running time (on-line/off-line or start/stop times) can indicate average demand over a long period of time.

When establishing compressed air demand for a new system, you must consider operating pressure requirements and the duty cycle of individual equipment.

Equipment using compressed air is rated by the manufacturer for optimum performance at a certain pressure and air flow. To design a compressed air system that delivers uniform pressure, it is necessary to ensure that all tools and equipment work efficiently within a narrow pressure range. If this cannot be done, you have the option of operating the entire system at the higher pressure and regulating pressure down as required, adding a booster compressor to increase pressure for a particular application, or installing two independent

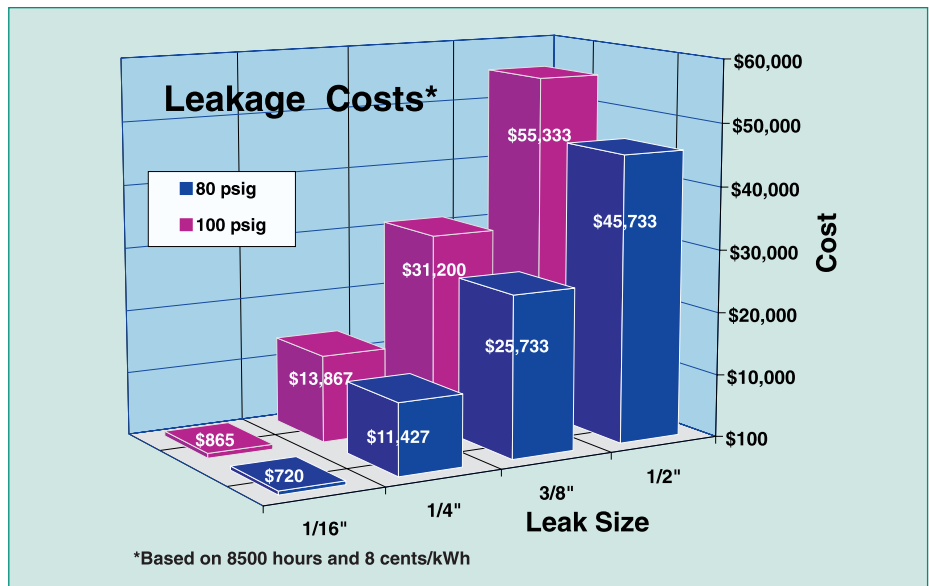

Flow Chart: Existing System

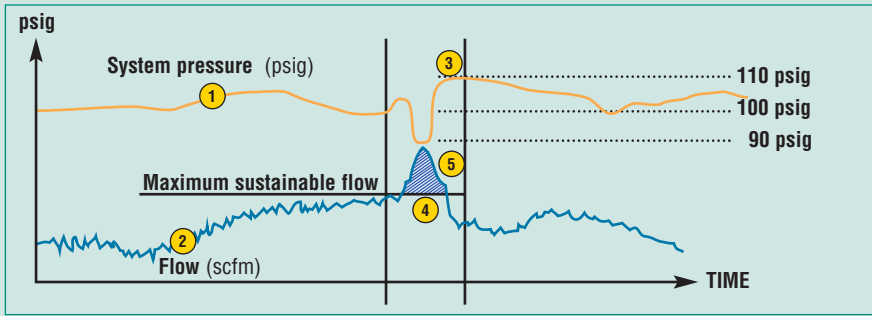

This is a typical flow chart reading which can be used to determine actual demand and flow pattern in existing systems. Flow and pressure are inversely related, as can be seen at Points 1 and 2. Pressure drops below the desired low pressure set points of 100 psig to 90 psig at Point 3 because the system cannot deliver the needed flow at Point 4. This can be remedied by adding compressor capacity to supply the needed flow (hatched area), or more efficiently, by adding adequate storage capacity, or eliminating the peak demand.

Establishing Flow Demand In New Systems

Pneumatic Equipment	Paint Spraygun @ 1.5mm flat jet	Paint Spraygun @ 3mm flat jet	Blowgun @ 2mm	Screwdriver
Air Demand	5 scfm	12 scfm	8 scfm	14 scfm
Working Pressure	40 psig	90 psig	90 psig	90 psig
Number	2	1	1	1
Utilization Factor	50%	25%	10%	20%
Effective Air Demand	2 x 5 x 0.5 = 5 scfm	12 x 0.25 = 3 scfm	8 x 0.1 = 0.8 scfm	14 x 0.2 = 2.8 scfm
Total Demand:	5 scfm + 3 scfm + .8 scfm + 2.8 scfm			= 11.60 scfm
The following should be added to Total Demand:	for leakages		+10%	= 1.16 scfm
	for errors		+15%	= 1.74 scfm
	as a reserve		+20%	= 2.32 scfm
Total Delivery:	= 16.82 scfm			

Average flow demand in new systems can be determined by examining operating pressure requirements, compressed air requirements, and the duty cycle of existing equipment.

The total required air delivery in this example is 16.82 scfm (11.6 scfm + 1.16 scfm + 1.74 scfm + 2.32 scfm). Since the optimum duty cycle of a screw compressor is 100% (although this may vary for other compressor types), the required screw compressor must have a free air delivery of at least 16.82 scfm at a gauge pressure of 110 psig to account for pressure differential in the compressor controls and other pressure losses.

air systems working at different pressures.

Leakage and artificial demand often represent a significant portion of your overall demand. All systems have leaks. Leakage can be measured in several ways while no pneumatic equipment is running: measuring the loaded running time of a compressor, timing the pressure drop of the receiver tank while all compressors are stopped, or measur-

ing leakage at the point of use. Your existing compressed air demand will also include artificial demand caused by excess system pressure that does not increase productivity. Artificial demand can be reduced significantly by installing a regulator at the point of use or a flow controller at the beginning of the distribution network.

What Air Quality Do You Need?

Different applications require different levels of compressed air quality. Because the cost of producing compressed air goes up with each level, it is important to meet but not exceed the required air quality level. If different sections of your plant require different levels of compressed air quality, it is more economical to treat smaller amounts of compressed air for a particular application rather than the entire air supply.

Quality Classes	SOLIDS Maximum Particle Size (microns)
0	as specified
1	0.01
2	1
3	5
4	15
5	40
6	—

Quality Classes	MOISTURE Dew Point	
	°C	°F
0	as specified	
1	-70	-94
2	-40	-40
3	-20	-4
4	3	38
5	7	45
6	10	50

Quality Classes	OIL Liquid and Gas	
	mg/m ³	ppm _{w/w}
0	as specified	
1	0.01	0.008
2	0.1	0.08
3	1	0.8
4	5	4
5	>5	>4
6	—	—

Built for a lifetime.™



Sigma Air Manager

Kaeser's Sigma Air Manager is the ultimate in compressed air system sequencing, monitoring, and management. Combining the benefits of modern industrial PC technology with Internet technology to provide unparalleled system control with real-time monitoring and HTML reporting. Optional software provides enhanced historical charting and reporting as well as remote access capabilities from virtually any location.

What Are Your Supply Requirements?

Compressed air supply is provided by air compressors. Your compressed air supply, utilizing sufficient storage and proper distribution, must meet your compressed air demand. If supply, storage, and distribution are not in tune, excessive pressure fluctuation will occur, resulting in increased operating cost and reduced productivity.

Most compressors are controlled by line pressure. Typically, a drop in pressure signals an increase in demand, which is corrected by increased compressor output. Rising pressure, indicating a drop in demand, causes a reduction in compressor output. Compressors use various capacity control systems to monitor these changes in pressure and adapt the air supply to the changing air demand. One of the more efficient is a load/no load control which runs the compressor at full load or idle, accommodating the demand variations.

Total plant supply can be provided by either a single compressor or a multiple compressor installation which can be centralized or decentralized. Single compressor installations are best suited to smaller systems or systems which operate almost exclusively at full output. Multiple compressor installations offer numerous advantages including: application flexibility (the ability to efficiently adjust to shift demand variations); maintenance flexibility; the option of centralized or decentralized operation; floor space flexibility; and backup capability.

How Much Storage Do You Need?

Your compressed air storage system consists of all the compressed-air containing vessels in your compressed air system. Sufficient storage is critical and represents available energy that can be released or replenished at any time as required.

The air receiver tank typically makes up the bulk of total storage

capacity. Because some compressor controls (start/stop and on-line/off-line) depend on storage to limit maximum cycling frequency at demands less than 100% of supply, a properly sized receiver tank prevents excessive cycling.

A properly sized receiver tank also provides sufficient storage capacity for any peaks in demands. During peak demand periods, a poorly designed system will experience a drop in pressure as air in excess of system capacity is taken from the system. Because not all compressors in a multiple compressor system remain on-line at all times, the actual air supply at any given time can be less than the total system capacity. During the time required to bring additional compressor capacity on line, stored compressed air can be used to prevent any pressure drop in the system. The amount of storage capacity needed depends on the amount of excess demand in cubic feet, available pressure differential between the compressor station and point of use, compressor start-up time, as well as the time available to replenish stored compressed air.

Flow controllers are also extremely important. Installation of a flow controller after the receiver tank is essential for providing additional compressed air when needed without downstream pressure fluctuations. The flow controller basically works like a precision regulator, increasing or reducing flow to maintain constant line pressure. It also provides the necessary pressure differential between the receiver tank and the system to create storage without changing system pressure downstream.

How To Determine The Best Distribution System?

Your compressed air distribution piping is your means for transporting compressed air and represents your link between supply, storage, and demand.

The ideal distribution system provides a sufficient supply of compressed air at the required pressure to all locations

Single vs. Multiple Compressors

Figure 1. Optimized Response to Fluctuating Demand

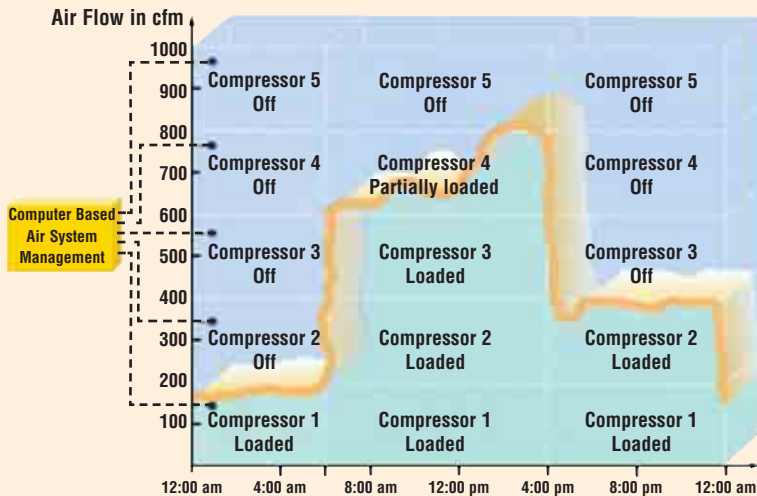

Multiple compressor systems offer several advantages over single compressor systems. Among these are the ability to adjust to variations in shift demand, and to apply computer-based air system management, providing proper flow and pressure with the highest overall efficiency.

Figure 2. Operating Cost* Savings

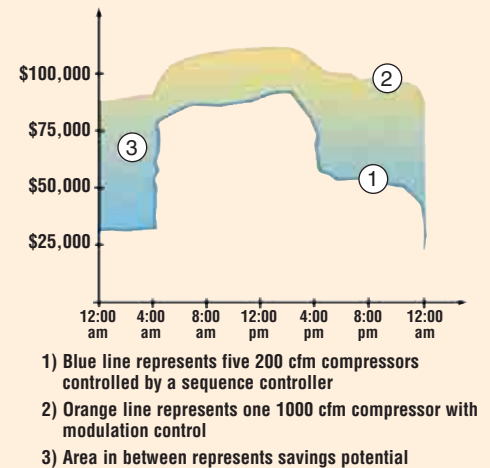

- 1) Blue line represents five 200 cfm compressors controlled by a sequence controller
- 2) Orange line represents one 1000 cfm compressor with modulation control
- 3) Area in between represents savings potential

*\$0.30 / 1000 cfm

Figure 1 shows the optimized response to fluctuating demand. Five compressors are operated by a computer-based air system controller which selects the minimum number of compressors needed to satisfy demand. This set-up offers significant operating cost savings as compared to a single compressor installation (Figure 2), while also increasing system reliability by providing back-up in case of malfunction or compressor maintenance requirements.

where compressed air is needed. A network of pipelines is used to supply different locations with compressed air. The flow of compressed air in pipelines, however, creates friction and results in pressure drop. Pressure drop in the pipelines should, ideally, be no more than 1 to 2 psi.

The following steps can be taken to reduce pressure drop:

- ▶ reduce the distance the air must be transported
- ▶ reduce the friction through the pipes by increasing pipe size and eliminating unnecessary elbows, valves, and other flow restrictions
- ▶ reduce the flow rate of air through the system
- ▶ select smooth bore piping

- ▶ minimize the drop in pressure across the system components
- ▶ eliminate leaks.

Friction loss is higher in longer pipes and in pipes with a smaller diameter. An effective way to reduce pressure drop is to use a loop system that provides two-way flow at any point in the system, cutting the flow in each pipe path in half and reducing compressed air velocity.

Even more important than pressure drop caused by friction, however, is that resulting from the system components themselves. This drop typically ranges from 5 to 25 psid and can be controlled, through careful equipment selection and proper maintenance.

KAESER COMPRESSORS

Built for a lifetime.™



Engineering Expertise

With decades of combined experience in compressed air systems and design, Kaeser's highly trained engineers provide expert applications assistance. From complex installations and challenging environments to facilities with limited space, Kaeser can design and lay out a system to meet the specified requirements for performance and reliability.

Kaeser uses state-of-the-art CAD systems to lay out the proposed system. Plus, our three-dimensional, virtual walk-through tour of the proposed system allows the end user to experience the complete installation. Virtual modeling allows all options to be considered. Variables such as distance, diameters, equipment arrangement, location, accessories and connections can be reviewed and modified, if necessary, prior to installation.

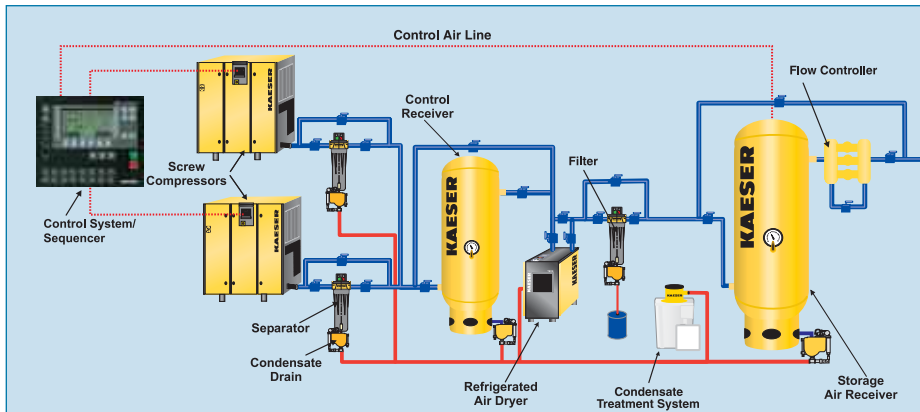

Optimized Compressed Air System

This diagram depicts multiple compressors controlled by a system controller, followed by clean air treatment and a storage air receiver with a flow controller. This setup ensures optimal use of energy.

What Are Some Important Layout Considerations?

The exact layout of your compressed air system will depend on the interplay of the system elements discussed previously: air demand, air quality, air supply and storage requirements, and distribution considerations.

Although information on compressed air generation and use is widely available, most compressed air users design and install the distribution system themselves. Only experienced compressor professionals can provide the information necessary to design a truly effective system because of the complexity and the number of design criteria involved. Any customer wanting to make full use of the compressed air that is available should consult with one of these companies.

Important installation considerations are: adequate ventilation, foundation requirements, compressor room requirements, and piping materials.

There are five basic methods of ventilation: natural ventilation; forced ventilation with an exhaust fan; ducted ventilation to the outside without a damper for air recirculation (suitable for ambient temperatures above 32°F); ducted ventilation with circulating air damper for winter operation, mixing warm air with cold intake air (suitable for intake temperatures below 32°F), or an exhaust

air duct vented to the outside during summer, and space heating during winter.

There are two ways to ventilate a room with multiple compressors. One way is to add the horsepower of all the compressors and ventilate the room as if a single compressor of that horsepower were in the room. A better way, is to provide each compressor with a separate intake air opening. To determine the size of the intake opening, add up the drive power of all the compressors and determine the cooling air flow and the required intake air opening for the total drive power. Divide the area of this opening into smaller intakes, proportional to the relative size of the compressors. Note that in general, no intake ducting is required.

Foundation requirements depend on the size and type of air compressor. Packaged rotary and small reciprocating compressors (25 hp or less) can be installed without any special foundation. For larger reciprocating compressors extensive foundations are required.

Special foundations are not required for base mounted rotary screw compressors as long as the compressor features vibration insulation mounts.

What are the Installation Considerations?

Compressors, especially medium or large compressors, should be installed in a special compressor room that is clean, dust-free, dry, and cool. If possible, the compressor room should be located in the north side of the building, with all heat-dissipating pipes and machinery being well insulated. To avoid frost and corrosion from condensate accumulation, the temperature in the room should not fall below 40°F. Compressor units should be easily accessible and lighting should be adequate for maintenance and inspections. Because air-cooled compressors require sufficient cooling air flow, the temperature in these rooms should not exceed 95°F. For compressors with drives up to 25 hp, natural ventilation is generally sufficient, but larger compressors and smaller compressor rooms will require forced ventilation. Dryers are another item often overlooked. Proper placement and/or cooling ducts/fans may be required for proper operation and long service life.

There are several ways to install compressed air lines. They can be installed in channels and shafts, which will avoid any construction obstacles.

However, this arrangement is more complicated and expensive than other solutions and may make access to piping difficult. Burying the air lines underground has the advantage of low cost, but makes repairs and maintenance extremely difficult and also requires rust-proof material. Another option is installing compressed air lines above the ground with supports and suspensions. This relatively low-cost option can present construction obstacles. For outdoor installations, pipe freezing can only be avoided if the compressed air has been dried to a pressure dew point below the lowest outside temperature.

Piping is critical to a compressed air system's reliability and efficiency. Before laying the pipes, material choice, dimensions, layout, conditions on-site, and future needs must all be considered. Piping must be rugged enough for the existing work conditions, provide minimum possible pressure loss and leakage, and be easy to maintain. Compressed air lines can be either black piping, galvanized, copper, or stainless steel. Each has advantages and disadvantages which should be carefully evaluated.

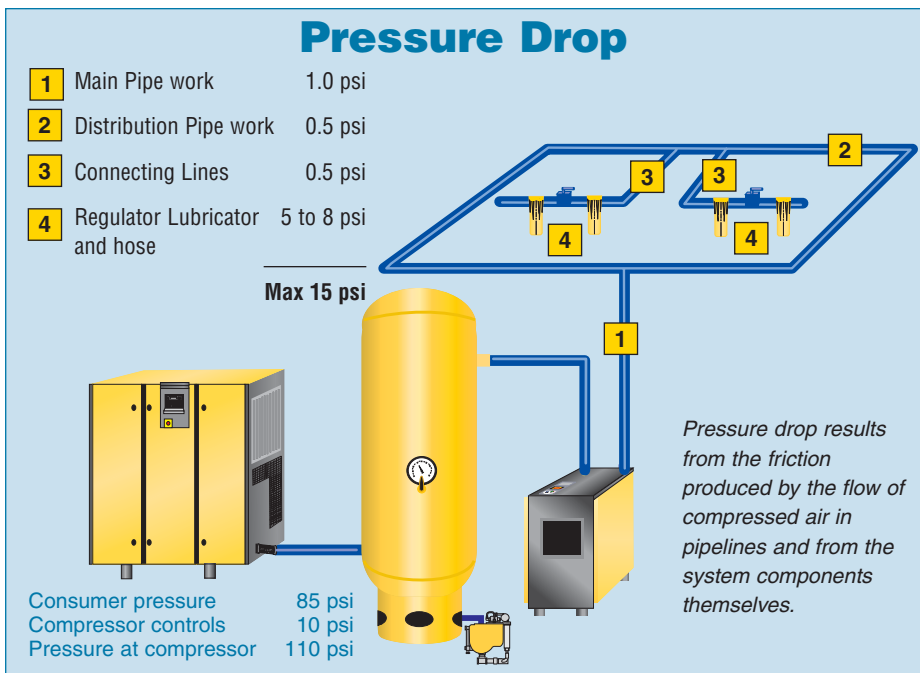

Rules of Thumb

- Every 2 psi pressure drop costs 1% of compressor horsepower in efficiency
- Compressors and dryers should be located in a dry, clean, cool (40 to 100°F), and well ventilated area. Allow enough room around the compressor and air treatment equipment for proper air flow and maintenance accessibility.
- Locate one air receiver near the compressor to provide a steady source of control air, additional air cooling, and moisture separation. A large storage receiver should be located downstream of the dryer and filters to act as a buffer for demand surges and controlled by a flow controller
- Air distribution piping should be of sufficient size to minimize pressure drop and allow for expansion.
- Piping in a loop system is recommended with all piping sloped to accessible drain points. Air outlets should be taken from the top of the main line so that possible moisture will not enter the outlet.
- The minimum amount of storage recommended is one gallon per cfm of capacity. This should be increased to 4-10 gallons per cfm of capacity for systems with sharp changes in demand.
- Under average conditions, every 100 cfm of air compressed to 100 psig produces 20 gallons of condensate per day which needs to be treated.

Typical Initial Pressure Drops

	Initial	Replace at:
Separator	1 psid	N/A
Filter	1 psid	10 psid
Refrigerator air dryer	2 to 6 psid	*
Desiccant air dryer	2 to 5 psid	*

*Some dryers have built-in filtration systems. These filter elements must be replaced when the pressure differential reaches 10 psid, or earlier to save energy.

Limiting pressure drop caused by system components is crucial for the efficiency of the whole system. Evaluate initial pressure drop carefully when selecting equipment and maintenance intervals.



Mission Statement

We strive to earn our customers' trust by supplying high quality Kaeser air compressors, related compressed air equipment and premium blower systems. Our products are designed for reliable performance, easy maintenance, and energy efficiency. Prompt and dependable customer service, quality assurance, training, and engineering support contribute to the value our customers have come to expect from Kaeser. Our employees are committed to implementing and maintaining the highest standards of quality to merit customer satisfaction. We aim for excellence in everything we do.

Our engineers continue to refine manufacturing techniques and take full advantage of the newest machining innovations. Extensive commitment to research and development keeps our products on the leading edge of technology to benefit our customers.

KAESER COMPRESSORS

Built for a lifetime.™

Corporate Headquarters:
Kaeser Compressors, Inc.
P.O. Box 946
Fredericksburg, VA 22404
(800) 777-7873
Fax: (540) 898-5520
www.kaeser.com

Certified Management Systems



© 2005 Kaeser Compressors, Inc.
All rights reserved. 12/05
USGUIDE3

Compressed Air System Glossary

Air flow: Volume of free air in cfm.

Air receiver tank: Tank used for compressed air storage.

Artificial demand: Additional air consumption caused by excessive system pressure.

Capacity: The amount of air flow delivered or required under some specific conditions. May be stated as acfm, scfm, or cfm FAD.

Cubic feet of air per minute (cfm): Volume delivery rate of air flow.

Cubic feet of air per minute, free air (cfm FAD): cfm of air delivered to some specific point and converted back to ambient air (free air) conditions.

Actual cubic feet per minute (acfm): Flow rate of air measured at some reference point and based on actual conditions at that reference point.

Inlet cubic feet per minute (icfm): cfm flowing through the compressor inlet filter or inlet valve under rated conditions.

Standard cubic feet per minute (scfm): Flow of free air measured at a reference point and converted to a standard set of reference conditions (e.g., 14.5 psia, 68°F, and 0% relative humidity).

Demand: Flow of air under specific conditions required at a particular point.

Discharge pressure, rated: Air pressure produced at a reference point.

Discharge pressure, required: Air pressure required at the system inlet.

Dual control: Load/unload control system that maximizes compressor efficiency. Compressor is normally operated at full load or idle, and is stopped and restarted automatically depending on demand.

Duty cycle: Percentage of time a compressor unit can operate at full load over a thirty minute period.

Flow meter: An instrument used to measure flow rate, pressure, vapor, or gas flowing through a pipe.

Load factor: Ratio of the average compressor load to the maximum rated compressor load during a given period of time.

Modulating control: Control system which will run the compressor at reduced output to accommodate demand variations. Running a compressor at less than full load results in a drop in compressor efficiency and thus an increase in operating costs.

Pressure: Force per unit area.

Pounds per square inch (psi): Force per unit area exerted by compressed air.

Pounds per square inch absolute (psia): Absolute pressure above zero pressure.

Pounds per square inch gauge (psig): Pressure difference between absolute pressure (psia) and ambient pressure.

Pounds per square inch differential (psid): Pressure difference between two defined points in the system.

Pressure dew point: Temperature at which water will begin to condense out of air at a given pressure. To ensure that no liquid water is present, the pressure dew point must be less than the lowest temperature to which the compressor air will be exposed.

Pressure drop: Loss of pressure in a compressed air system due to friction or flow restriction.

Conversion Formulas

	Multiply	by	To Obtain
Volume:	cubic feet/minute	0.472	liter/second
	gallons	0.134	cubic feet
	liters/minute	0.2642	gallons/minute
	cubic meters	35.315	cubic feet
Pressure:	inches mercury	0.4912	psi
	inches water	25.4	mm water
	psi	27.68	inches water
	bar	14.504	psi
Density:	pint water	1.042	pounds water
	gallon water	8.336	pounds water
	pounds water	7000	grains water
Power:	horsepower	0.7457	kilowatts
	horsepower	2544.43	Btu/hour
Temperature:	degrees Fahrenheit	(degrees-32) x 0.556	degrees Centigrade